

ME18 MF Plu.

single acting hydraulic cylinders

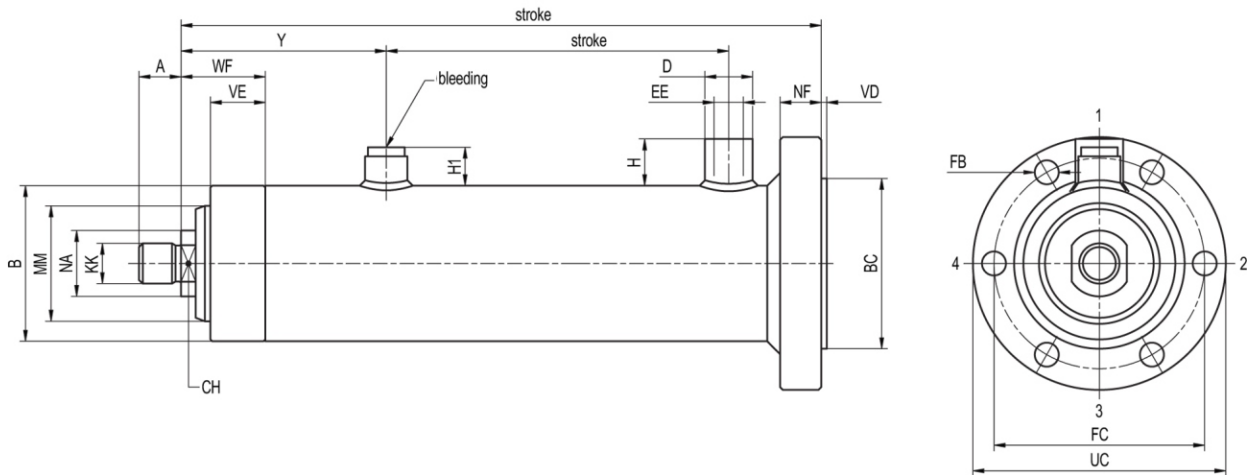

All dimensions are in millimetres.

MM Ø	A	B Ø	CH	H*	H	H1 max	D Ø	EE	KK	NA	WF	VE	Y ± 5	PJ** ± 5	V**
25	17	50	12	37	15	21	20	G 1/4	M 12×1.25	14	25	10	65	0	25
32	19	60	15	37	15	21	20	G 1/4	M 14×1.5	17	25	10	70	0	25
40	16	60	22	42	16	21	26	G 3/8	M 16×1.5	25	40	25	88	0	30
50	16	75	22	42	16	21	26	G 3/8	M 16×1.5	25	45	30	91	0	35
63	23	85	30	42	16	21	26	G 3/8	M 22×1.5	34	46	30	112	0	35
70	35	95	36	42	16	21	26	G 3/8	M 35×1.5	40	47	30	112	0	35
80	35	105	36	42	16	21	26	G 3/8	M 35×1.5	40	49	30	112	0	40
100	45	140	46	48	18	21	30	G 1/2	M 45×1.5	50	52	35	137	0	40
125	58	180	60	57	21	21	38	G 3/4	M 58×1.5	65	55	35	155	0	40
140	65	190	65	57	21	21	38	G 3/4	M 65×1.5	70	55	35	165	0	60

* Block valve can be mounted into the attachment.

** In strokes shorter than 50 mm, mounting dimensions ZJ and PJ shall lengthen by the length of the stroke - 50mm.

** In strokes exceeding 500 mm, mounting dimensions ZJ and PJ shall lengthen by the length V, due to additional piston rod guidance.

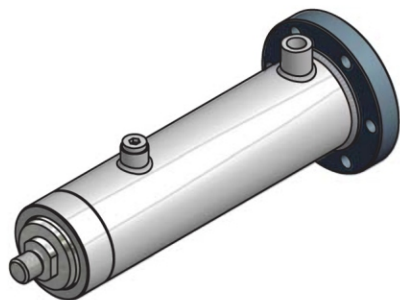

MM Ø	ZP**	VD	NF	BC Ø e8	FC	UC	FB
25	90	3	14	65	85	104	11
32	98	3	17	75	95	118	11
40	118	3	17	75	95	118	11
50	125	3	22	90	115	138	13
63	149	3	25	100	125	158	13
70	149	3	27	115	145	178	17
80	149	3	27	125	155	188	17
100	186	3	35	165	205	245	21
125	209	3	40	225	275	335	30
140	221	3	40	225	275	335	30